

Hire Instructions

13km/h Manual Incline Treadmill



WARNING:

Befit strongly recommend never starting or stopping your treadmill while standing on the mat. Follow the recommended mounting and dismounting procedures to avoid possible accidental injuries. Befit also recommend placing your treadmill on a mat or carpet offcut to protect your flooring from wear and minimize noise and vibration during use.

Any adult using exercise equipment should ensure that children are not in the vicinity when the unit is in use. Any children using equipment should be supervised by an adult at all times. The unit when not in use still represents a danger to unsupervised children, so it should be moved to prevent access or the unit should be rendered inoperable, so they cannot turn it on.

MOUNTING

Stand with feet on the footpads either side of the mat. Turn the unit on and start at lowest speed. Holding the handrails for support, place one foot, then the other on the mat and walk in a normal manner. When balanced and comfortable, release hold on the handrails and walk naturally

DISMOUNTING

Turn unit to low speed. Holding the handrails for support, place one foot at a time onto side foot rails. Turn off unit and remove safety key. Switch off at power point.



SAFETY KEY

For the treadmill to operate, the safety key must be in position where indicated on the console. During use, attach the key clip to your clothes to provide a rapid means of stopping the unit. If the key is taken from its position, power to the unit will be cut and the treadmill will automatically stop.

COMPUTER OPERATION

START - Press to start exercise at initial speed 0.5 mile/h.

STOP - Press during workout, and the treadmill will stop by gradually reducing the speed.

QUICK SPEED SELECT - Press to select your desired running speed with 2, 3, 4, 5, 6, 7, 8 mile/h

SPEED UP/DOWN

1. Press to increase/decrease exercise speed by 0.1 mile/h.

2. Press to select training time under program workout model

3. Press to select the desired training target (Time, Distance, Calorie) under training target control workout mode)

MODE

Press to select training target workout mode (Time-Distance-Calorie count down)

PROGRAM

Press to select workout program (P01-P02-...-P10).

FOLDING AND MOVING THE TREADMILL

Lay the treadmill on the ground. Grasp the console rod with one hand, and disengage the lock by pulling towards the console rod as shown in the diagram.

Lift the console until the upright posts click into place.

Flip the console housing and handrail into place.

Pull the locking knob on the handle bars to release the handlebar lock, lower handlebar so that it clicks into place.

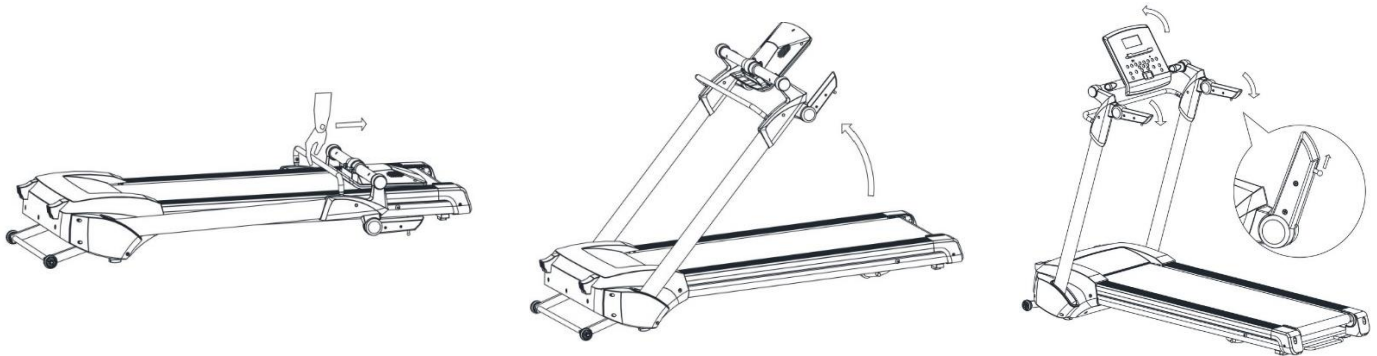

INCLINE ADJUSTMENT

The incline is adjusted by moving the incline bar under the deck. With the treadmill standing upright, swing the incline bar “up” (towards the rear of the treadmill deck). To put the deck into the inclined setting, swing the bar “down” (towards the front of the treadmill).



GENERAL EXERCISE GUIDELINES

Beginning an exercise program is dependent upon your current fitness level. If you are overweight or have been inactive for a period of time, start slowly and progress gradually. Initially, to become accustomed to the treadmill and exercising, work at a comfortable level that you can maintain for at least 5-10mins. From here, try to increase duration to 20-30mins.

As a general rule when first starting, exercise at a level where you can still maintain a normal conversation without constantly being out of breath.

Try watching television or listening to music when exercising to help the time pass.

Wear comfortable clothing with supportive and cushioned footwear.

Drink plenty of fluids before, during and after exercise.

Stop exercising if you feel ill, faint or exhausted and seek medical advice.

Give your exercise program time to work. It may take up to four weeks before you notice any changes to your weight or fitness level, so be patient and persistent.

TROUBLESHOOTING

While your treadmill has been checked and cleaned prior to being hired, problems can sometimes arise, especially if you have had the unit for a long period of time. Make sure that the red safety key has been placed on the bottom of the console first, however if this does not fix the encountered problem, call your hiring agent.